

DYNAPLAQUE MAXIDYN



Version 4: 22/12/2023



1 General

The Dynaplaque Maxidyn performs platform bearing capacity measurements in accordance with the NFP 94-117-2 standard from 20 MPa to 250 MPa.

Among its advantages:

- **Easy installation** on most of simple cab pickup in the market.
- **High performances.** Up to 60 measurement per hour without leaving the vehicle and with only one operator.
- **Choice of manipulation system:**
 - o Crane vehicle: The crane can move the loading plate to either side of the pickup and under excavated area.
 - o Fork vehicle: The loading plate is put on the ground using a hydraulic fork on the side of the vehicle.
- **Ergonomic software.** The acquisition and export Maxidyn software is used on a windows tactile tablet.
- **Automatic generation of report.** With included GPS measurement and mapping.
- **Great After sale support.** With phone support and same day shipping to minimize down time.



Max extension of the Dynaplaque Maxidyn.

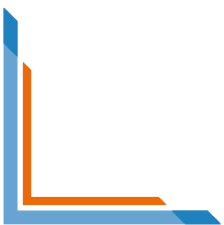



Figure 1 : Right and left movement.

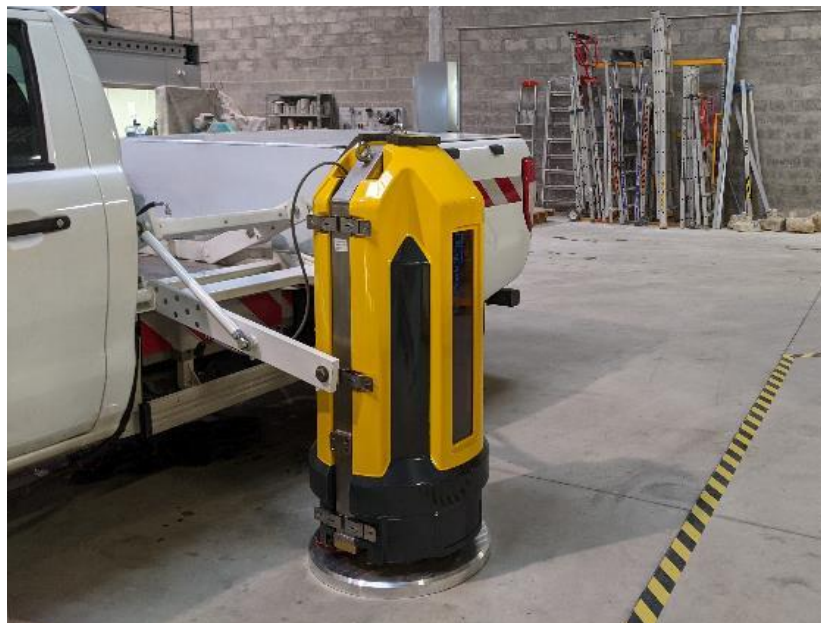
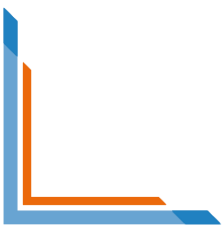

Figure 2 : Fork vehicle.





2 Loading plate

The loading plate follows the French standard NFP 94-117-2 “Modulus on dynamic loading using the Dynaplaque”.

A 150 kg weight is dropped from 40 cm on a 600 mm plate to create a dynamic loading of 70kN on the platform under test. Load and displacement during impact are measured used to compute the dynamic loading bearing capacity.

The loading plate and its sensors are annually verified and calibrated to the national calibrations standards.

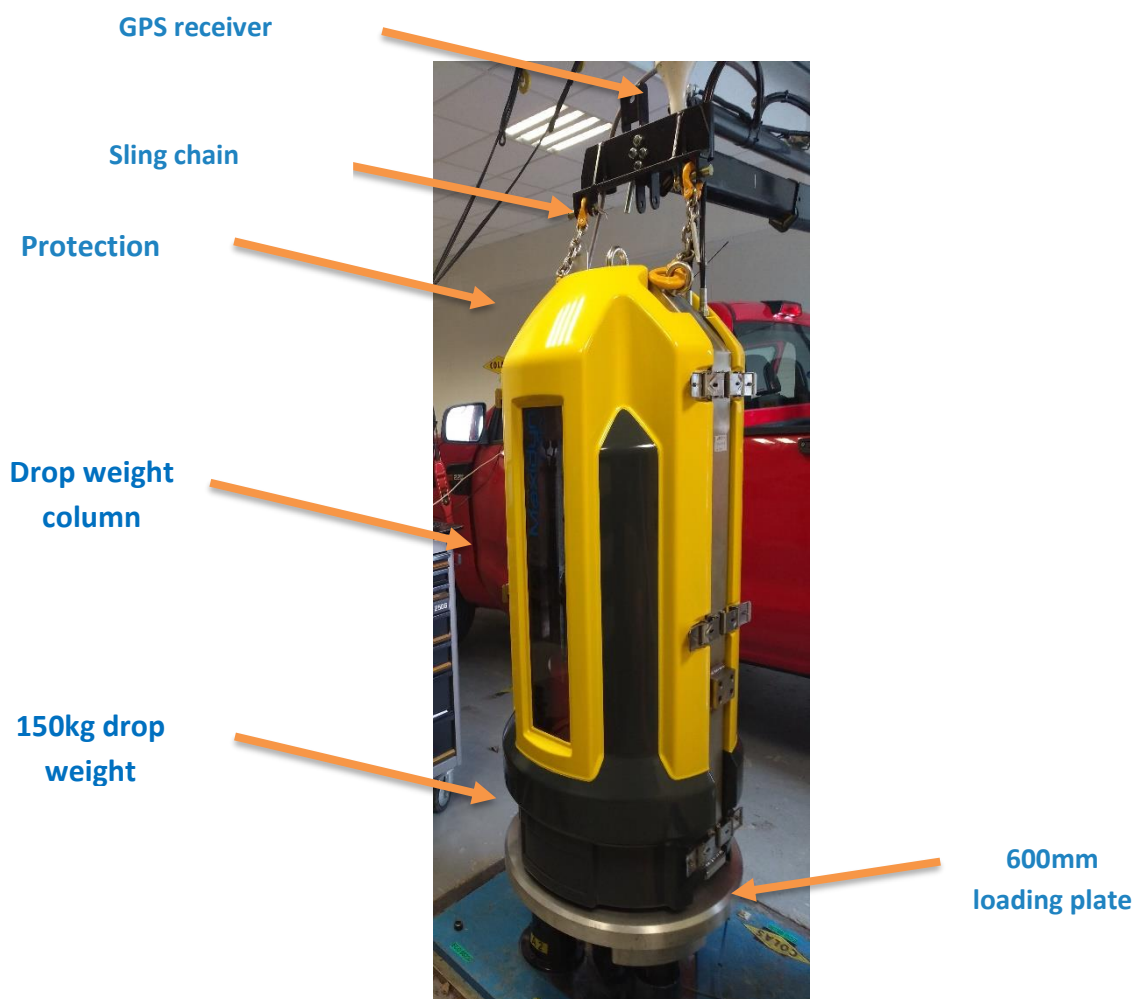

Loading plate on calibration bench.

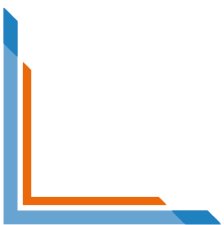



Drop hook

Central hydraulic cylinder

150kg drop weight



Loading plate assembly.

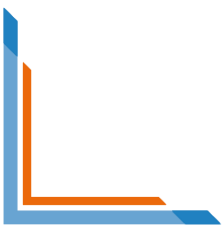



3 Crane type vehicle

3.1 Vehicle

The crane system is installed on a simple cab pickup vehicle. The vehicle options are chosen by the customers. The following pickup are validated by our technical department:

- Isuzu D-Max
- Ford Ranger
- Toyota Hilux

Marking of the vehicle including your logo is included and use the Maxidyn visual guideline comprising of the yellow stripe with Maxidyn name and the reflective strips class II.

The loading plate is manipulated by the hydraulics crane using a wireless remote. The sling chains allow for an easy rest on any ground configuration (slope, trench..).

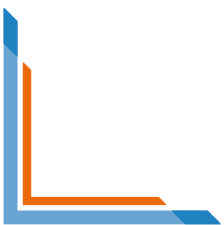



Hydraulic crane and wireless remote.

The loading plate can be put on the ground relative to the pickup as shown on the schematic below:

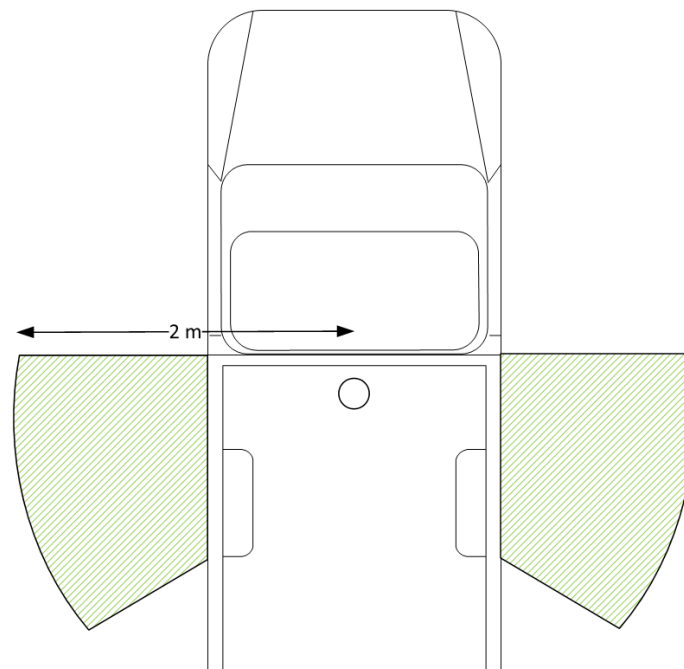

Measurement zone.

The hydraulic crane can put the loading plate on either side of the vehicle and below the ground level at around -50 cm to -80cm depending on the pickup used.

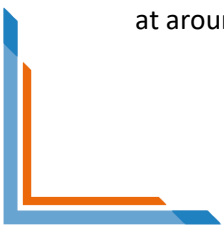



3.1 Loading plate side mount

The loading plate is held securely on the side of the pickup between two measurements with the help of a hook.

There is no need to put back the loading plate inside the pickup between measurement.



Side mounting of the loading plate during measurement





3.2 Pickup vehicle examples

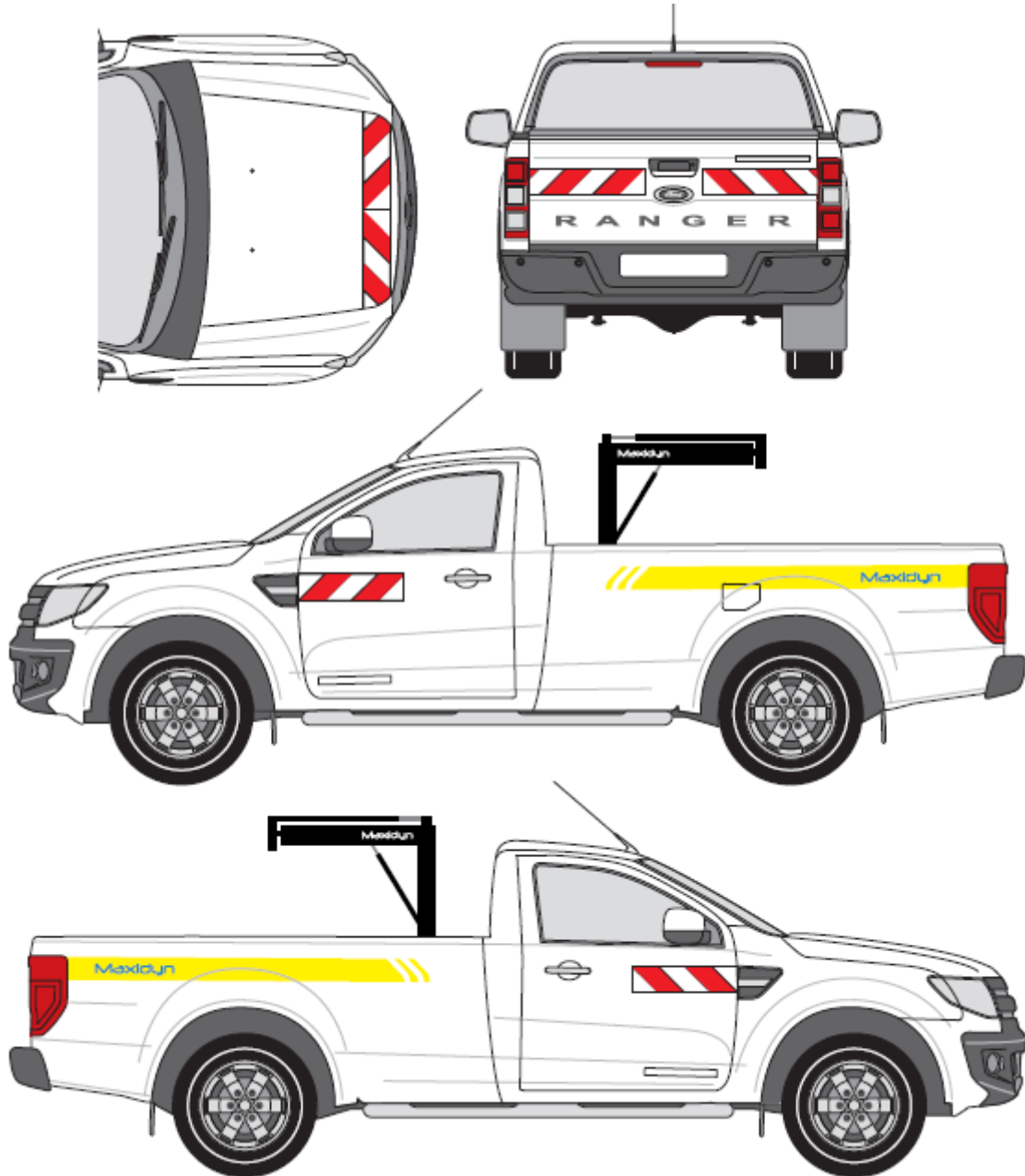

Vehicle marking.

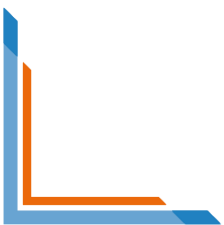



Maxidyn on Ford Ranger, Toyota Hilux and Isuzu DMax.



3.3 3.3 Vehicle installation

The installation of the crane and loading plate are done in our Courcouronnes (Ile de France) workshop.



Courcouronnes workshop.

The modification of the vehicle are minimal and are resumed on the next schematic.

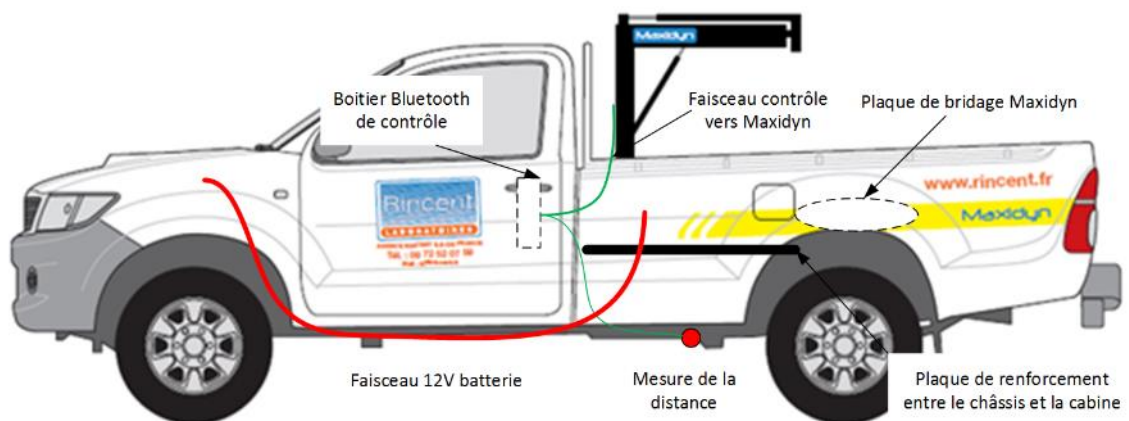

Vehicle installation.





3.4 Trunk



Trunk size.



Trunk fitting exemple.

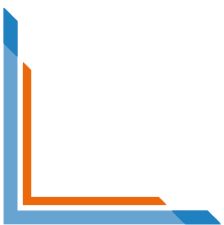



4. Fork type vehicle

4.1 Vehicle installation

Fork type vehicle installation is done on single cab Ford Ranger pickup. Other vehicle type can be used after validation of our technical department.

The loading plate is put on the ground using one or two hydraulic cylinders on each side of the plate.



Fork type vehicle installation

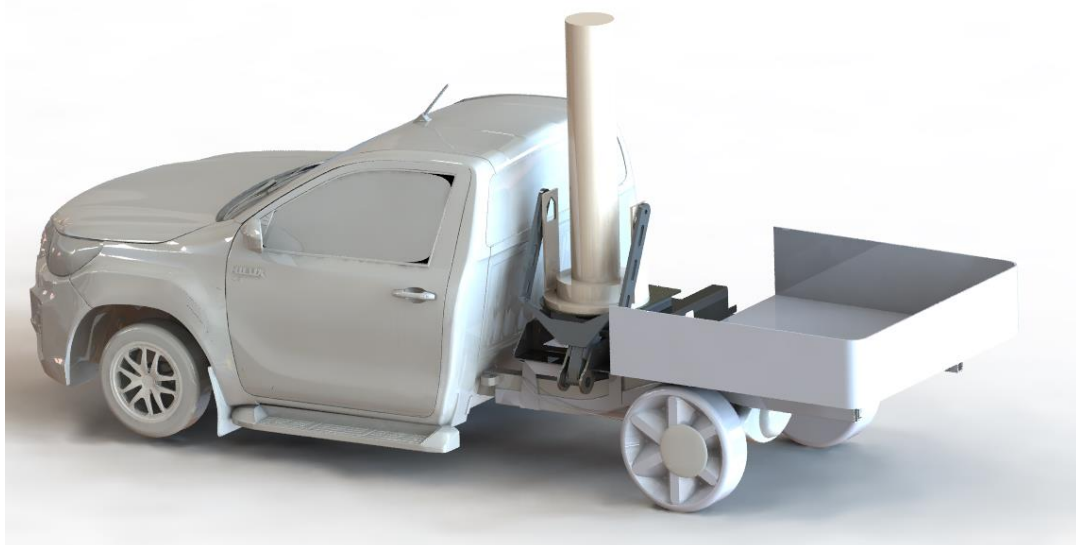

Single cylinder on a Toyota Hilux.

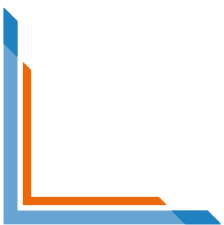



4.2 Measurement zone

The measurement zone is situated on the driver side of the vehicle.

The hydraulic fork can put the loading plate below -10 cm to -20 cm the ground surface. An extension system consisting of two extensions arms is available to put the loading late up to -80 cm below the ground surface.

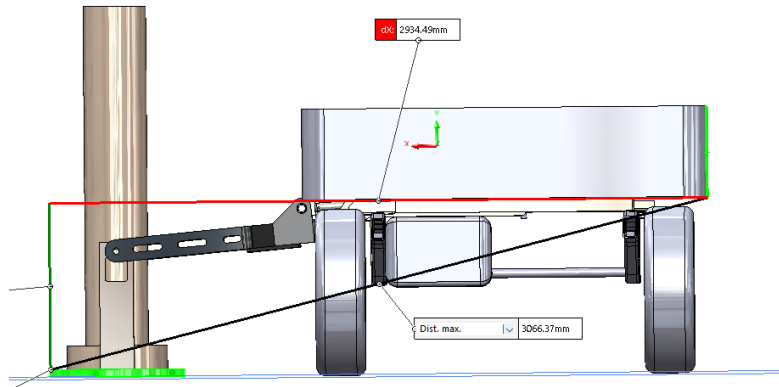

Measurement zone Hilux.

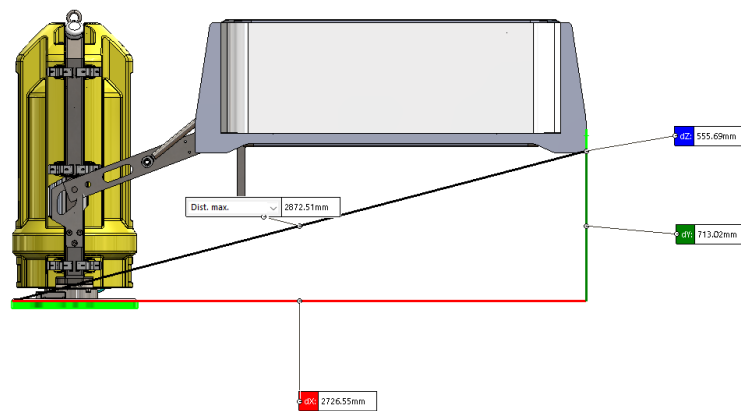

Measurement Zone Ranger.

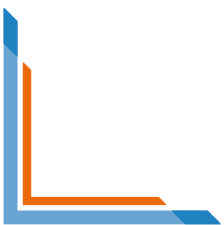



4.3 Hydraulic system

The hydraulic system is actuated using a hydraulic pump on the vehicle accessory belt. Hydraulic pump is automatically controlled by the acquisition system and is activated when pressing movement button of the wired remote and is deactivated after 15 seconds of inactivity or when the driver releases the handbrake.

A manual pump is also available in case of emergency



Hydraulic system.

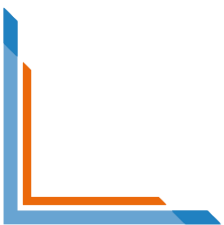



4.4 Trunk

A trunk can be fitted at the back of the vehicle. Most of the standard trunk from the manufacturer can be used.



4 Driver cabin installation

The installation in the driver cabin is the same for a crane type vehicle or a fork type vehicle.

For optimal use, we recommend to use a 10-inch tactile tablet on the front shield windows but the Maxidyn software can be installed on any Windows laptop with Bluetooth.

The tablet is used to:

- Control the loading plate and retrieve the measurement.
- Display the cartographic data using 4G/5G data connectivity.
- Upload measurement data for offsite processing.
- Report creation directly on site.





Driver cabin installation.



Tablet version 8 inches

Other type of laptop can be installed on request.

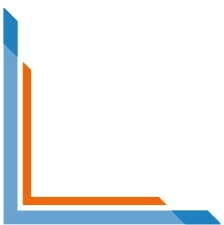



4.2 Specifications

Specifications	Value
Complete loading plate	340 Kg
Drop weight weight	150 Kg
Plate diameter	600 mm
Plate material	Aluminium
Drop height	45 cm
Load sensor	Max load: 125 KN Error: < 0.3% FS
Displacement sensor	Accelerometer Frequency range: 0.5Hz...7500Hz Resolution: 1µm
Measurable bearing capacity	Minimum 10MPa Maximum 250MPa.
Power	12V vehicle alternator
Data transfer	USB or Bluetooth
GPS	GPS Garmin Constellations GPS et Glonass +SBAS Precision de 1 to 3m

Specifications	Value
Crane weight	105 kg
Carrying capacity	10 kN/m
Max extension from vehicle	Depth from 50 cm to 80 cm Up to 100 cm on either side
Power	24V / 100A on external batteries Recharged using vehi
Wireless remote	Rotation/extension/up/down/dynaplaque

Hydraulic crane specification.

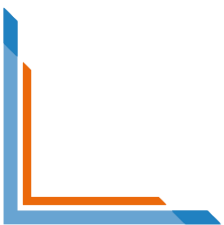

5 Softwares

5.1 Acquisition and reporting

The acquisition and reporting software *Maxidyn* can be installed in any windows computer without any licenses.

The graphical interface is aimed to easily and safely perform measurements:

- Single interface for all measurement functions.
- Button size adapted to tactile screens.
- Easy and fast operations. Only 3 steps to start making measurement.

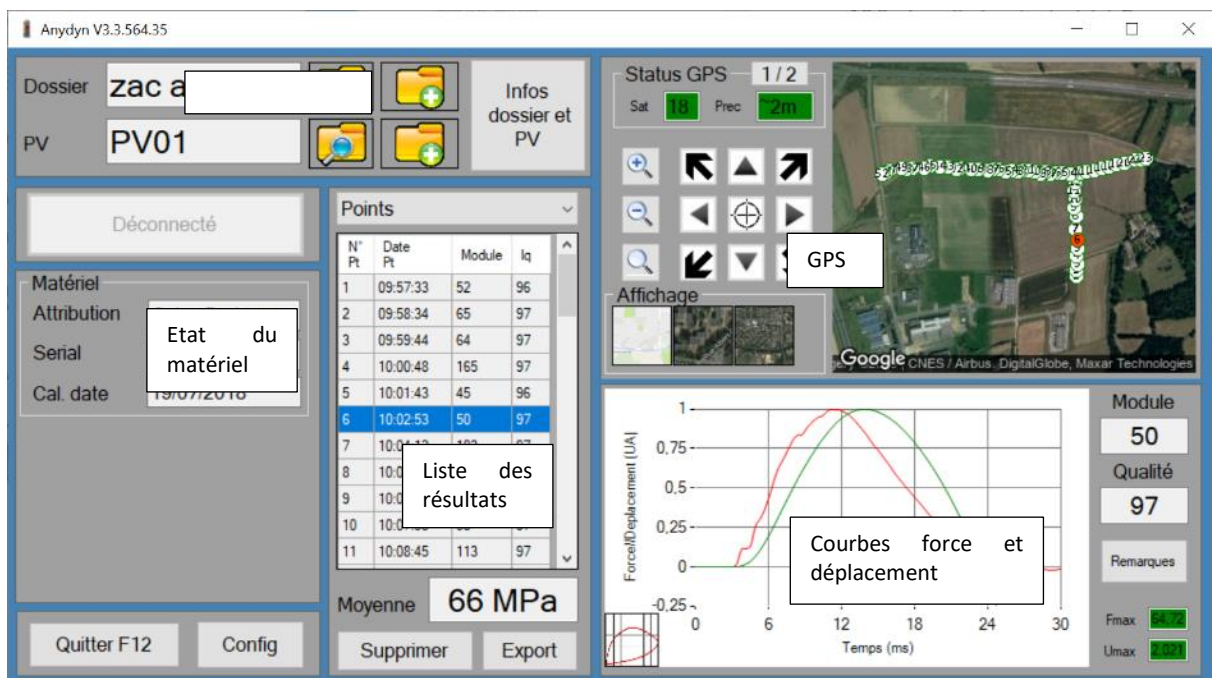

Maxidyn software.

5.2 Mapview cartographic reporting web application

The Mapview cartographic web application is a freely available website to visualize and export your data on a Google map style view.

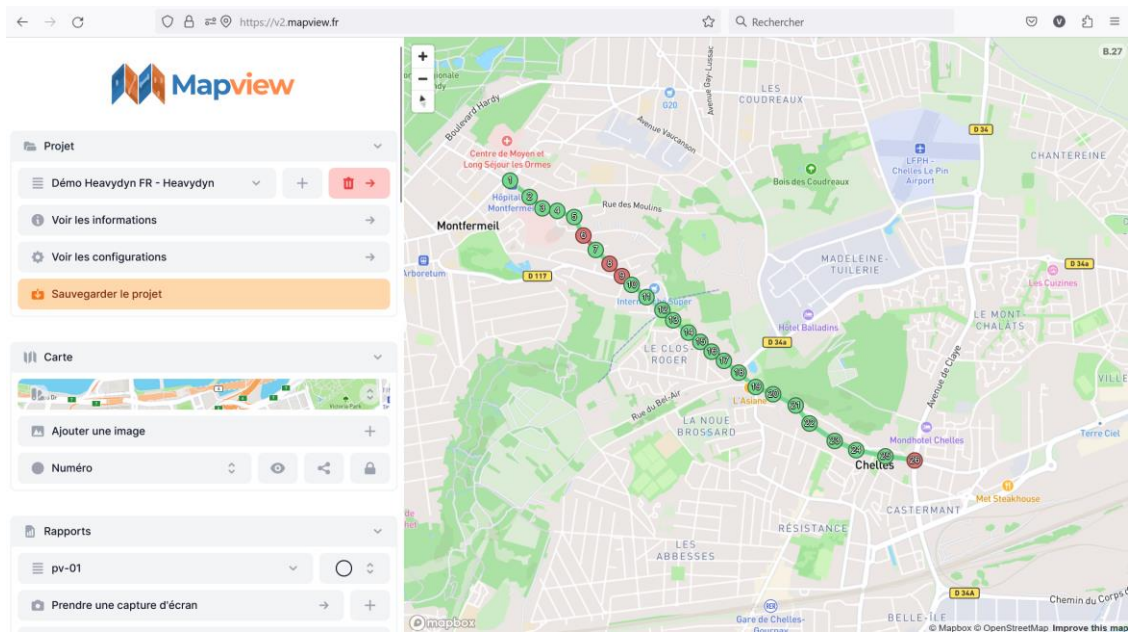

Application web Mapview

The export button is use to create automatically report using different customizable format:

- Excel template
- Database format in text

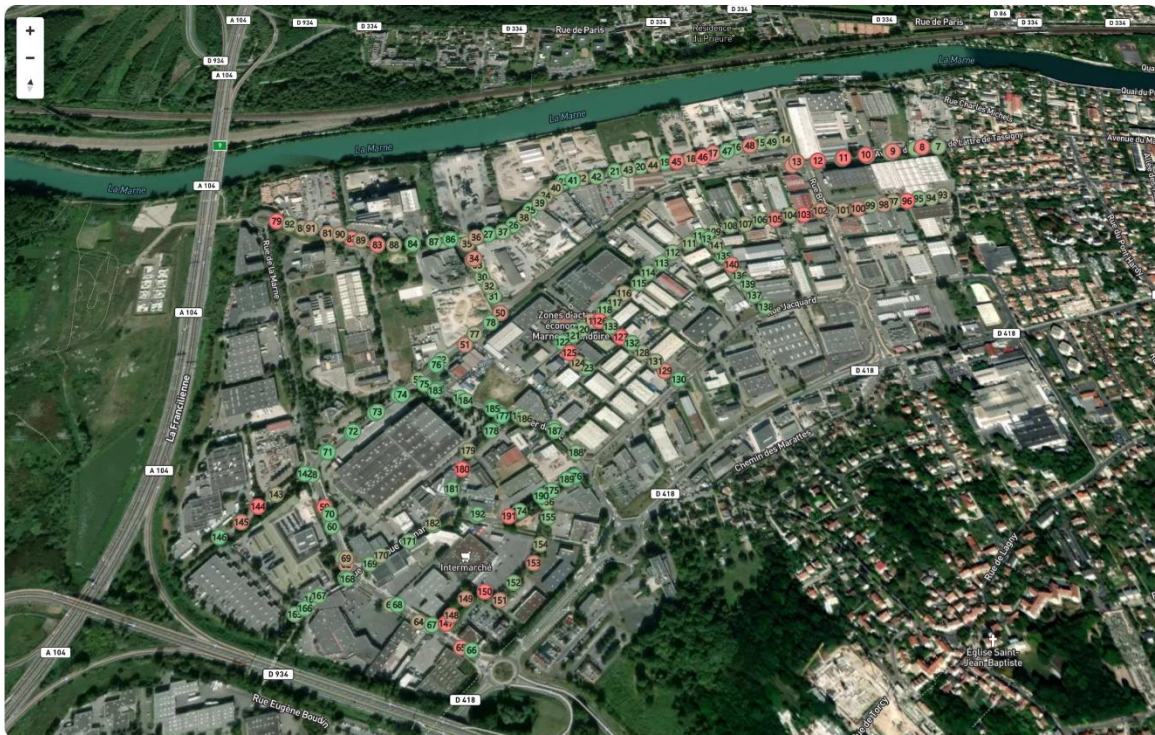



Rincent Ile de France Nord

Portance des plates-formes
Module sous chargement dynamique (Dyna plaque 2)
NF P 94-117-2

Raison sociale: LAB DIAG
SARL au capital de 80 000 €
LOT 311 - 14, rue de la Penne
Tremblay en France
9534 Rosny-Or de Seine CEDEX
Tel : 01.49.89.29.94

Responsable des essais : Raphaël DA CONCECAO
Téléphone : 01.49.89.29.94
Email : rdnord@rincent.fr

INFORMATIONS GÉNÉRALES			
Client : Erftage	Date des essais : 15/06/2018		
Chantier : CANAL DE BERRY	Numéro de dossier : 1232		
Localité : Ici	Date de rapport d'essai : 04/10/2018		

N° APPAREIL ET VERIFICATION METROLOGIQUE			
Modèle : Maxdyn2	Date d'étalonnage : 05/04/2018		
Numéro de série : MAX-104B	Plage de mesure : 10 à 250 MPa		

NATURE DU SUPPORT TESTÉ			
Etat du support : Bâtiment	Nature du support : Fond de forme		
	Nature du matériau : Grave naturelle		

SYNTHÈSE DES RÉSULTATS			
Nombre d'essais : 115	Module Edyn2 moyen = 10 MPa		
Seuil de réception Edyn2 (MPa) : 50	Edyn2 min = 17,8 MPa		
Nombre de points supérieurs au seuil de réception : 40	Edyn2 max = 159,8 MPa		

Commentaires :	Responsable des essais :	Validation :
	Rincent	Raphaël DA CONCECAO



Rincent Ile de France Nord

Portance des plates-formes
Module sous chargement dynamique (Dyna plaque 2)
NF P 94-117-2

Raison sociale: LAB DIAG
SARL au capital de 80 000 €
LOT 311 - 14, rue de la Penne
Tremblay en France
9534 Rosny-Or de Seine CEDEX
Tel : 01.49.89.29.94

Responsable des essais : Raphaël DA CONCECAO
Téléphone : 01.49.89.29.94
Email : rdnord@rincent.fr

RÉSULTATS DES ESSAIS

N° essai	Heure	Longitude	Latitude	Précision GPS (m)	Module Edyn 2 (MPa)	Commentaires
1	13:11:00	2,235798	47,123658	2	55	
2	13:13:00	2,235126	47,123983	2	22	
3	13:18:00	2,234465	47,124287	2	22	
4	13:26:00	2,233722	47,124608	2	29	
5	13:30:00	2,233009	47,124921	2	42	
6	13:32:00	2,23232	47,125222	2	44	
7	13:36:00	2,231682	47,125518	2	40	
8	13:38:00	2,230968	47,125825	2	50	
9	13:40:00	2,230291	47,126139	2	35	
10	13:42:00	2,229588	47,126444	2	39	
11	13:44:00	2,228849	47,126732	2	37	
12	13:47:00	2,22834	47,126982	2	63	
13	13:50:00	2,227949	47,127164	2	49	
14	13:52:00	2,227592	47,12735	2	35	
15	13:54:00	2,226849	47,127621	2	35	
16	14:13:00	2,225416	47,128299	2	58	
17	14:30:00	2,224796	47,12884	2	22	
18	15:10:00	2,226323	47,123421	2	117	
19	15:12:00	2,226808	47,123179	2	48	
20	15:14:00	2,227491	47,122875	2	47	
21	15:16:00	2,228377	47,122455	2	24	
22	15:18:00	2,229222	47,121961	2	38	
23	15:21:00	2,229879	47,121414	2	63	
24	15:32:00	2,240201	47,121143	2	62	
25	15:34:00	2,240757	47,120832	2	39	
26	15:36:00	2,241296	47,120142	2	43	
27	15:38:00	2,241862	47,119502	2	48	
28	15:40:00	2,242309	47,119198	2	47	
29	15:42:00	2,24283	47,118706	2	38	



Réseau de Laboratoires d'Essais et d'Analyses

Tremblay, le 17/09/2018

Chantier : N18.0134
Localité : MONTEAUX GARE
Date d'essai : 02/03/2018
Page 4 sur 17

PROCÈS-VERBAL D'ESSAIS
Essais au déflectomètre portable - Minidy™

IMPLANTATION DES ESSAIS



Rincent Ile de France Nord

Portance des plates-formes
Module sous chargement dynamique (Dyna plaque 2)
NF P 94-117-2

Raison sociale: LAB DIAG
SARL au capital de 80 000 €
LOT 311 - 14, rue de la Penne
Tremblay en France
9534 Rosny-Or de Seine CEDEX
Tel : 01.49.89.29.94

Responsable des essais : Raphaël DA CONCECAO
Téléphone : 01.49.89.29.94
Email : rdnord@rincent.fr

IMPLANTATION DES ESSAIS



Tous droits réservés. Toute réimpression ou utilisation non autorisée sans la permission écrite de la société est formellement interdite. Toute reproduction ou utilisation non autorisée sans la permission écrite de la société est formellement interdite.



6 Maintenance

Per standard requirement, the calibration and maintenance of the dynaplaque Maxidyn have to be done yearly.

Rincent ND Technologies provide a calibration and maintenance package with :

- Verification of the loading plate
- Revision of the hydraulic crane
- Oil and filter replacement
- Hydraulic crane control
- Calibration

Tree to five days are necessary for perform these operations.

7 After sale services

Rincent ND Technologies provide a fast and comprehensible support

- Reachable by email or a dedicated hotline in case of emergencies with response time below 15 minutes
- Warehouse with all necessary replacement parts with same day shipping

Site intervention during the warranty



Workshop

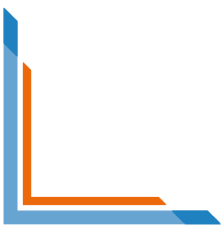



8 Warranty

Hardware and software are warranted by Rincent ND Technologies.

Rincent ND Technologies will repair or replace any defective parts at no additional charge of the product owner.

Hardware, excluding the vehicle is guaranteed for 1 (one) year from the date of commissioning the equipment.

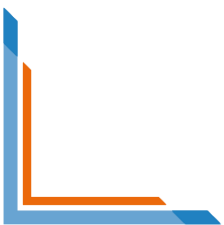



CONTACT

 ndt@rincent.fr

 +33 6 61 18 87 63

 4 bis rue du bois briard
91080 Courcouronnes



The appearance of the products and/or technical characteristics are subject to change without notice.

